

Hoisting Unit		
Electric hoist	type	MHL6-25 2/1 H12 V8
Capacity	t	5,0
Rope	mm	Φ15
Mode of operation	---	2m
Lifting height	m	12,0
Lifting speed	m/min	8
Output	kW	8,0
Speed of revolution	min <sup>-1</sup>	900
Current	A	19,1
Power Supply	---	3 ph / 400V / 50Hz

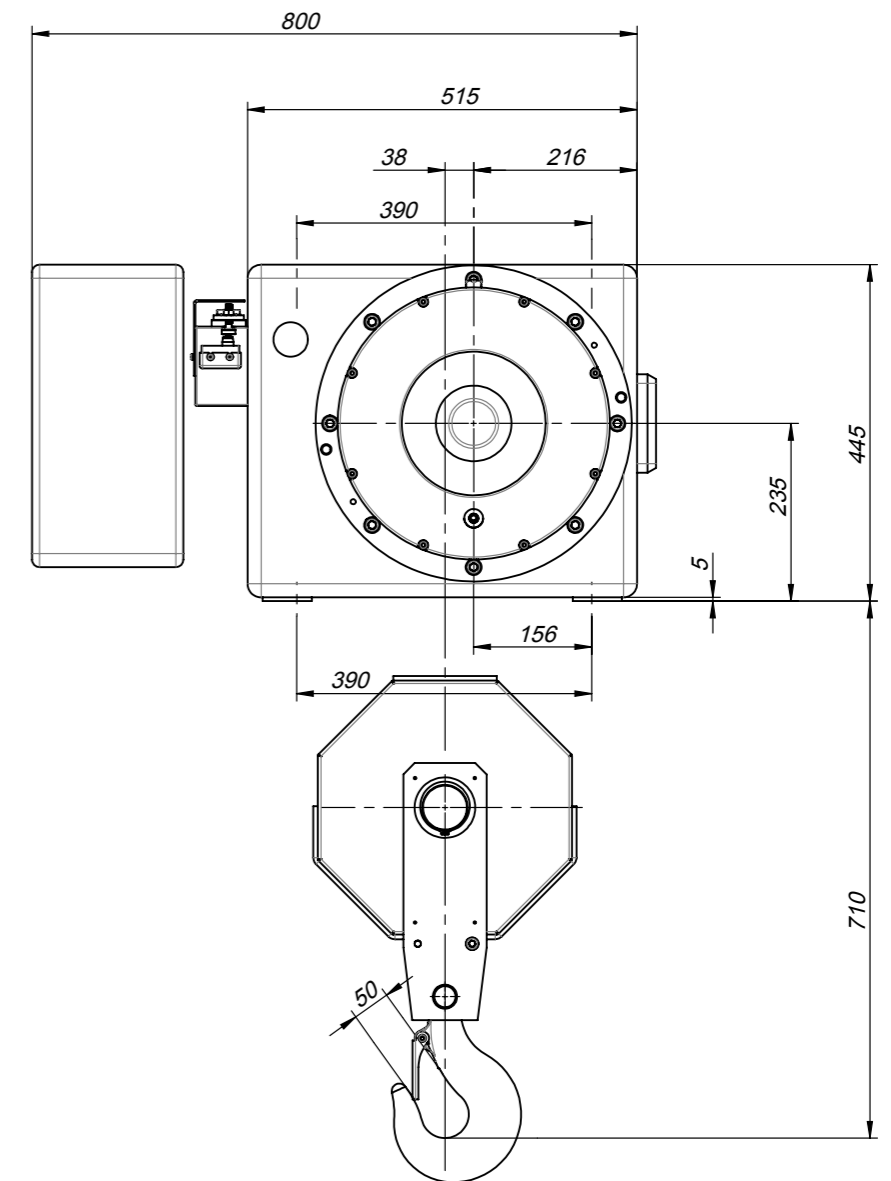

					Озн. на грапавост БДС-ISO 1302: Ra	Озн. на формата и разп. БДС-ISO 1101-1	Неозн. допуски БДС-ISO 2768
					БДС-ISO 128	Маса (kg) 541.18	Материал:
Изм.	Брой	Номер	Подпис	Дата			<b>balkancarpodem</b>
Разр.	Татарлиев		4.2.2022	Лист			
Пров.			4.2.2022	1/1			
Утв.	Кавалов		4.2.2022				
Наименование:					Мащаб	Кат. №:	
<b>Stationary hoist-Reeving 2/1</b>					1:10	Чертеж №: <b>MHL6-25 2/1 H12 V8</b>	